

**Elevacion frontal\_(Vista Principal)**  
Esc. 1 : 50



**Elevacion lateral\_(Vista secundaria)**  
Esc. 1 : 50

		<b>UNIVERSIDAD PRIVADA DE TACNA</b>	
		FACULTAD DE ARQUITECTURA Y URBANISMO	
TESIS: "APLICACIÓN DE LA METODOLOGÍA BIM PARA LA GESTIÓN Y CONSERVACIÓN DEL PATRIMONIO CULTURAL - PREFERENCIA Y CARGEL PÚBLICA DE TACNA, 2022"		I TALLER DE ASESORIA PERSONALIZADA PARA EL DESARROLLO DE TESIS DE INVESTIGACION EN ARQUITECTURA - MODALIDAD NO PRESENCIAL	
PLANO: <b>PLANO DE ELEVACIONES</b>		N. de LAMINA: <b>A-05</b>	
ASESOR: ARQ. ALDO RAUL GAMBETTA MONTALVO	TESISISTA: BACH. en ARQ. ROGER QUENTA AMONES	ESCALA: 1/100	FECHA: OCTUBRE 2022

09/11/2022 01:08:59 p. m.

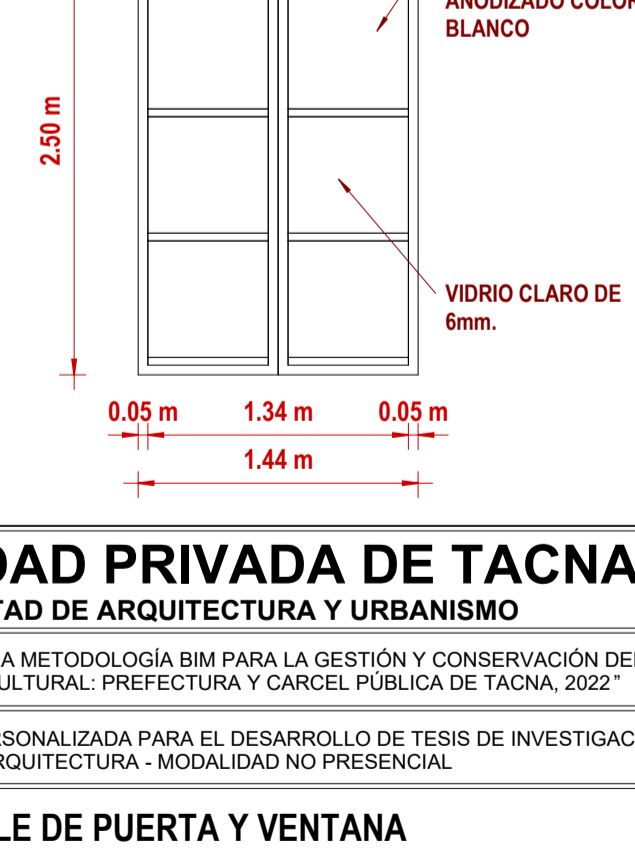
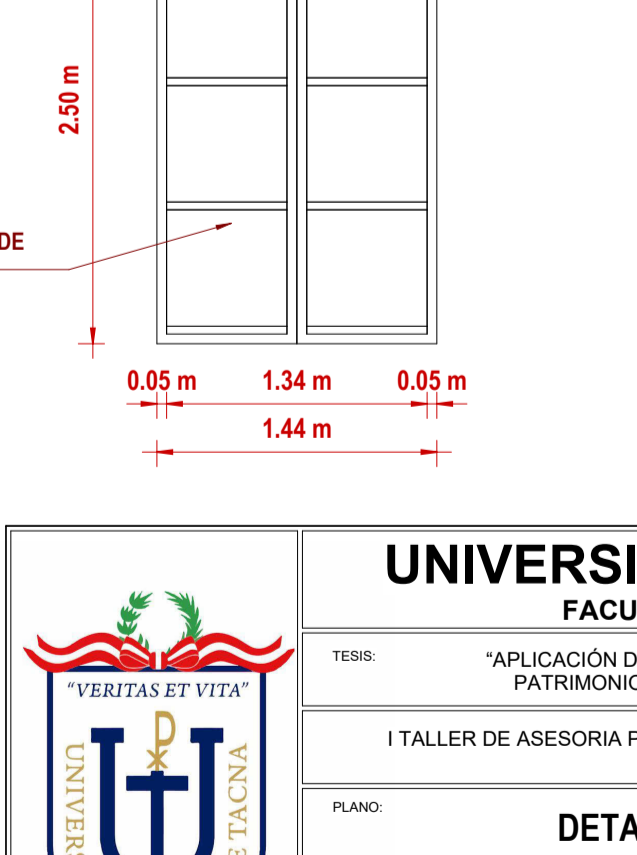
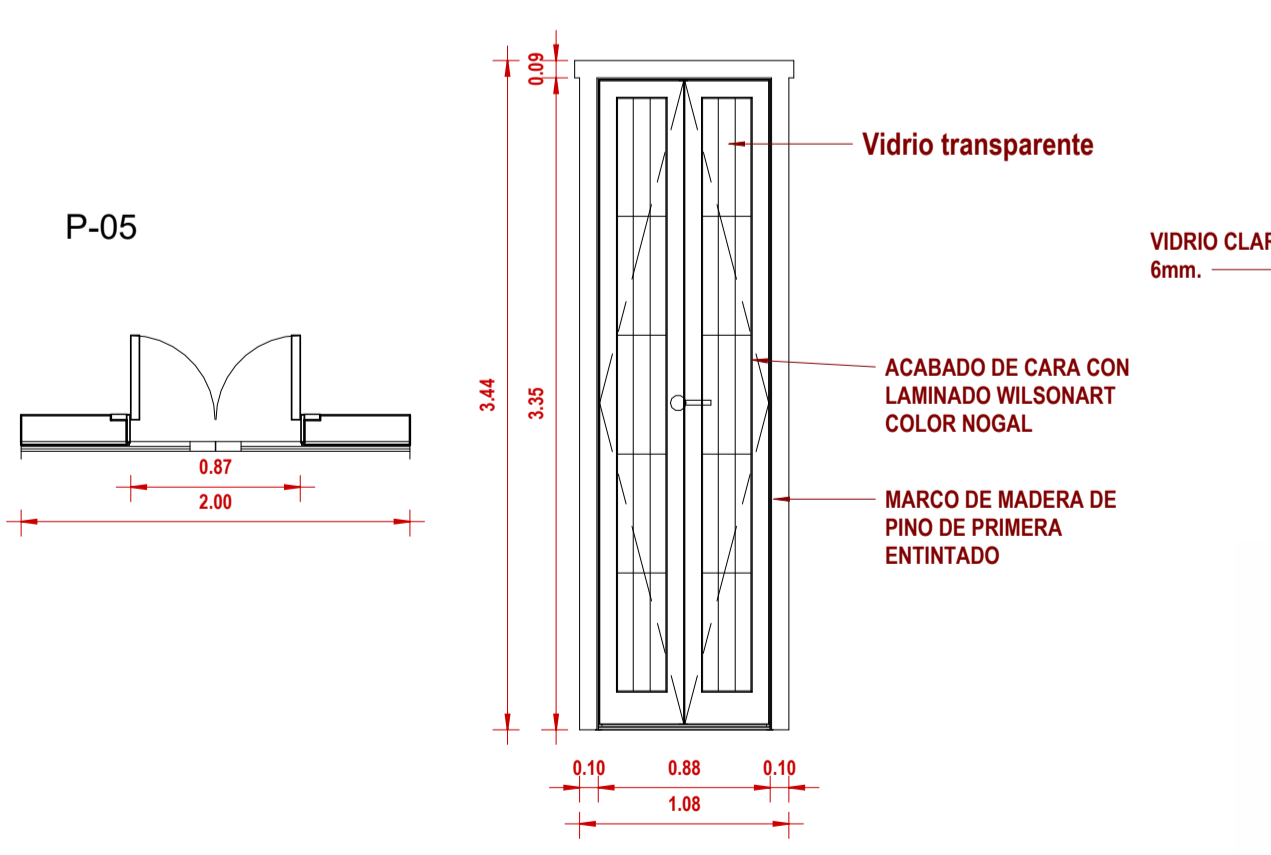
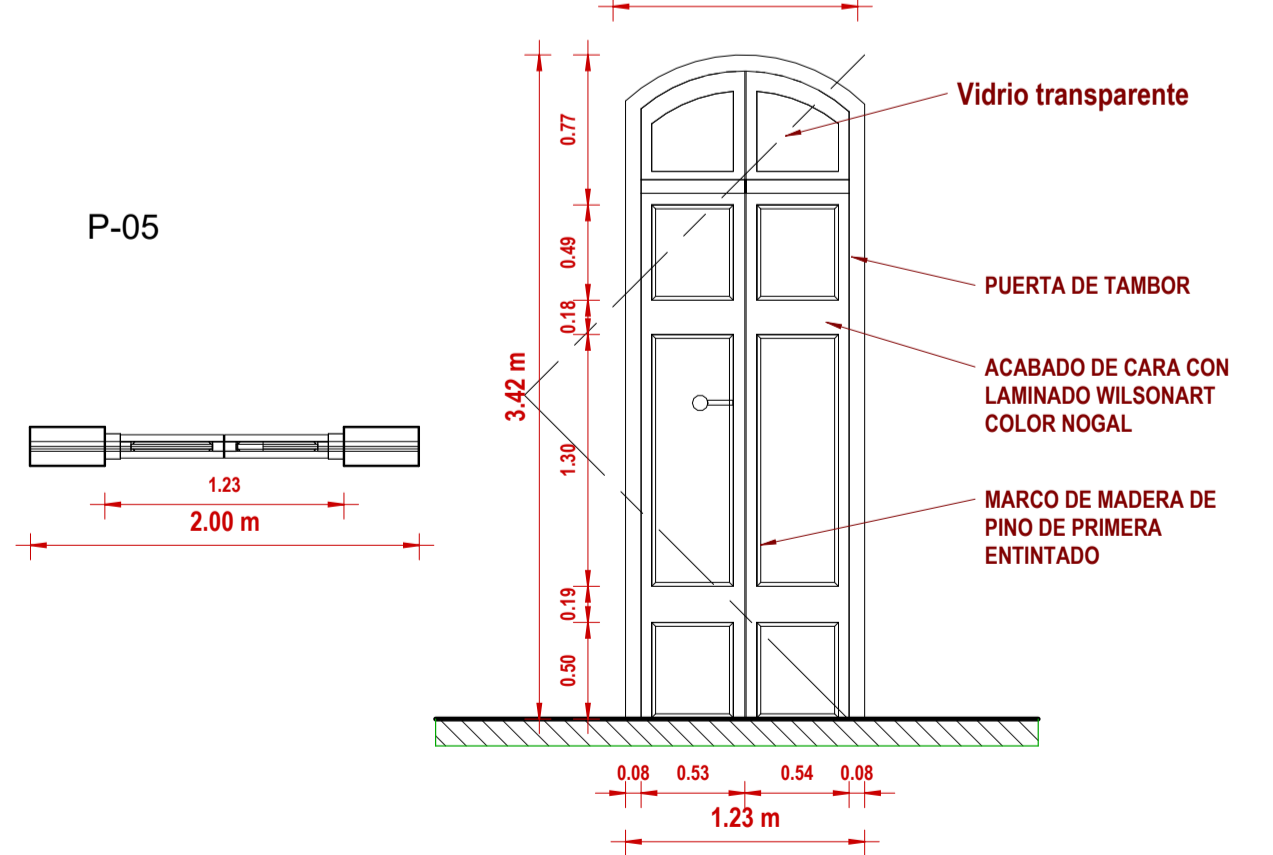
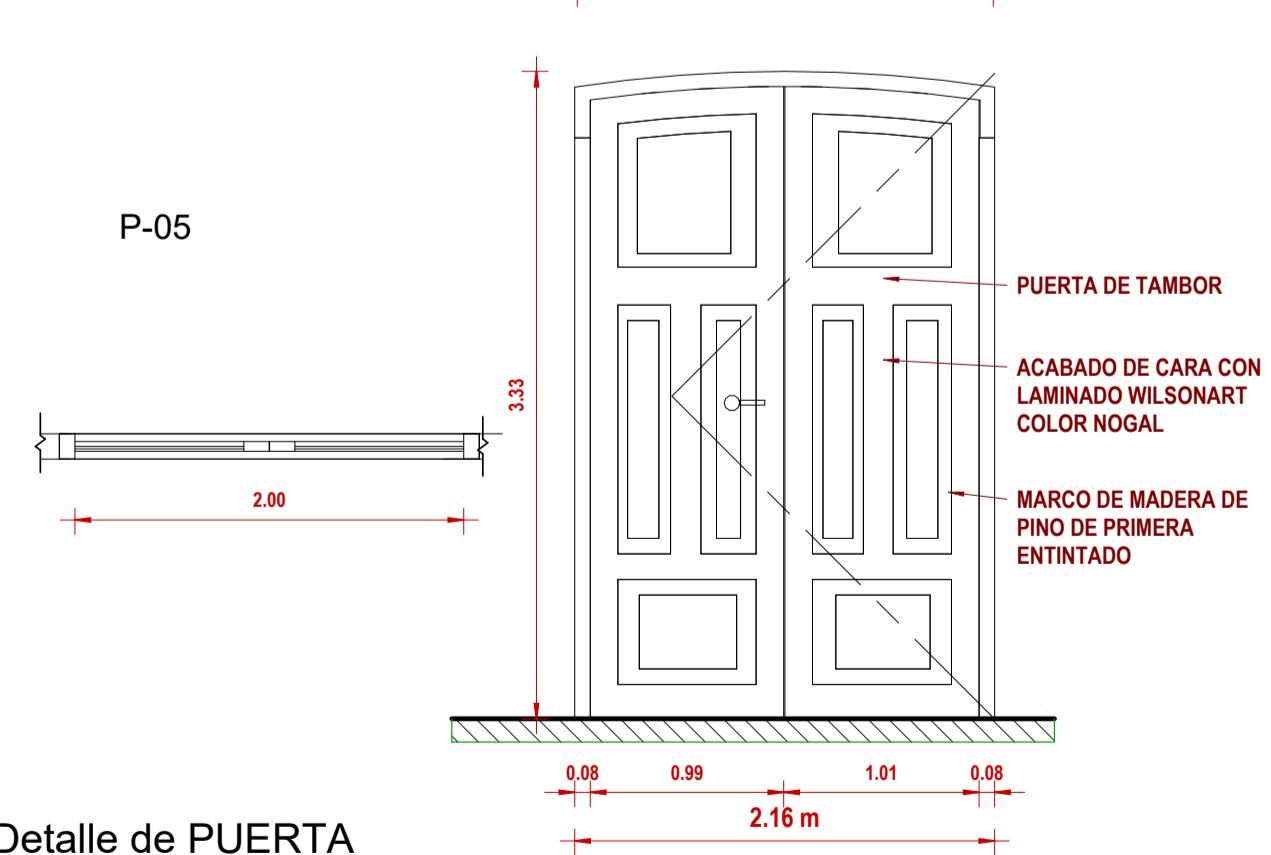
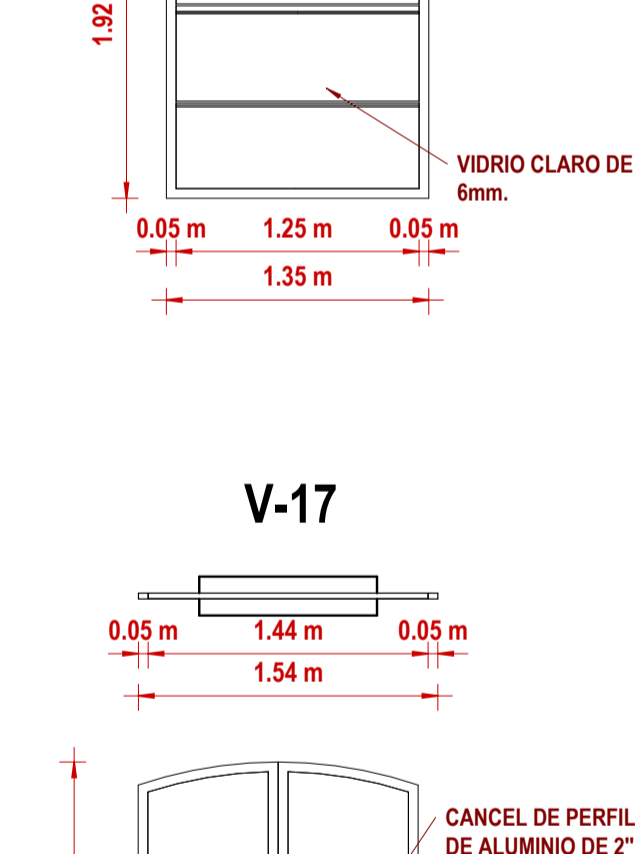
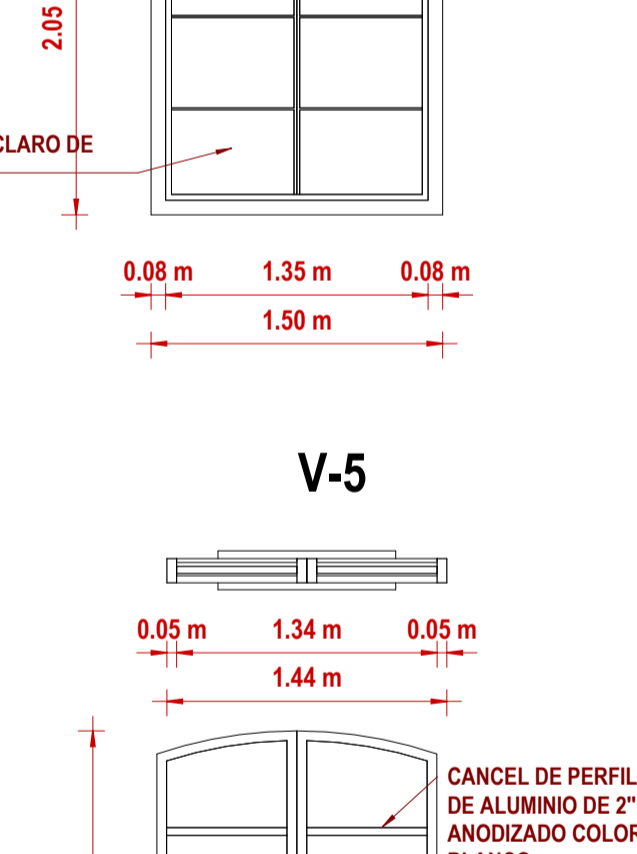
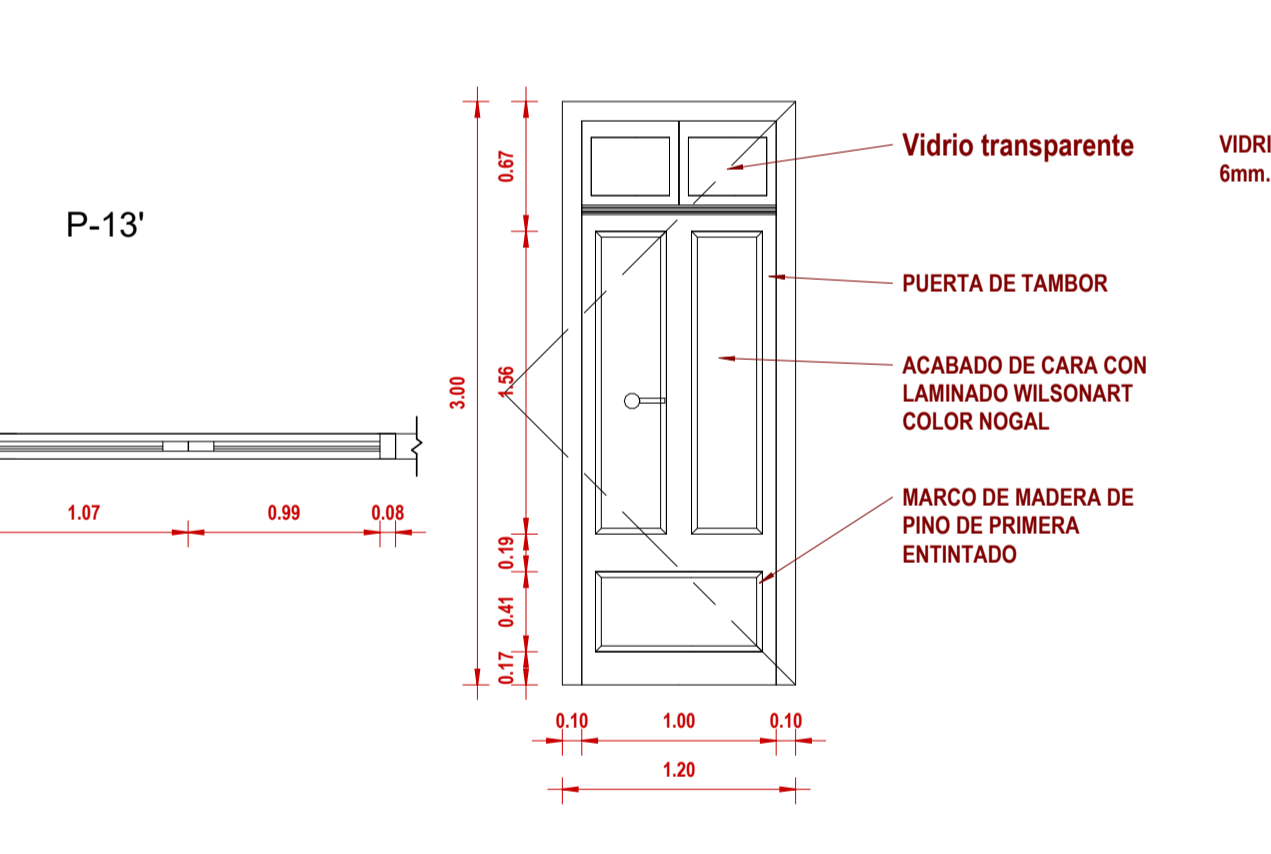
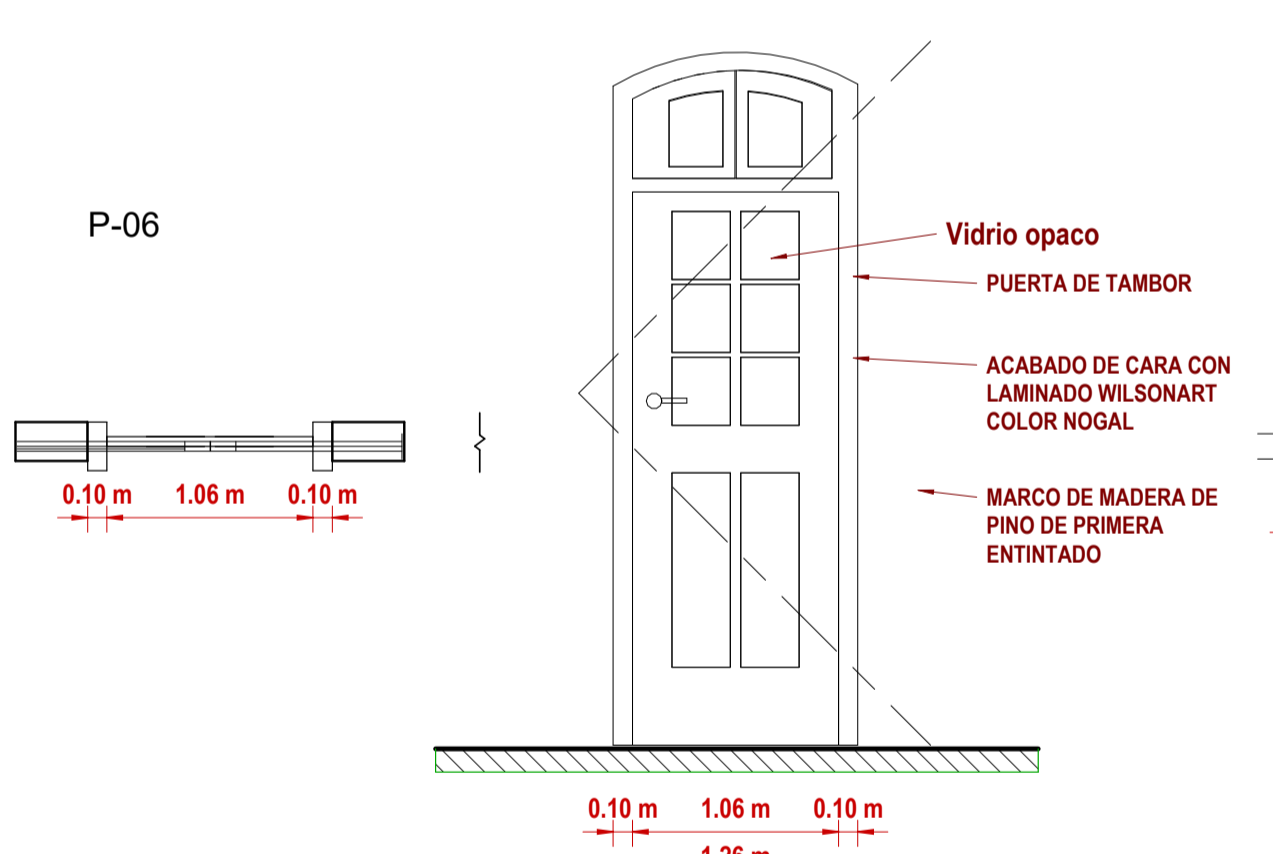
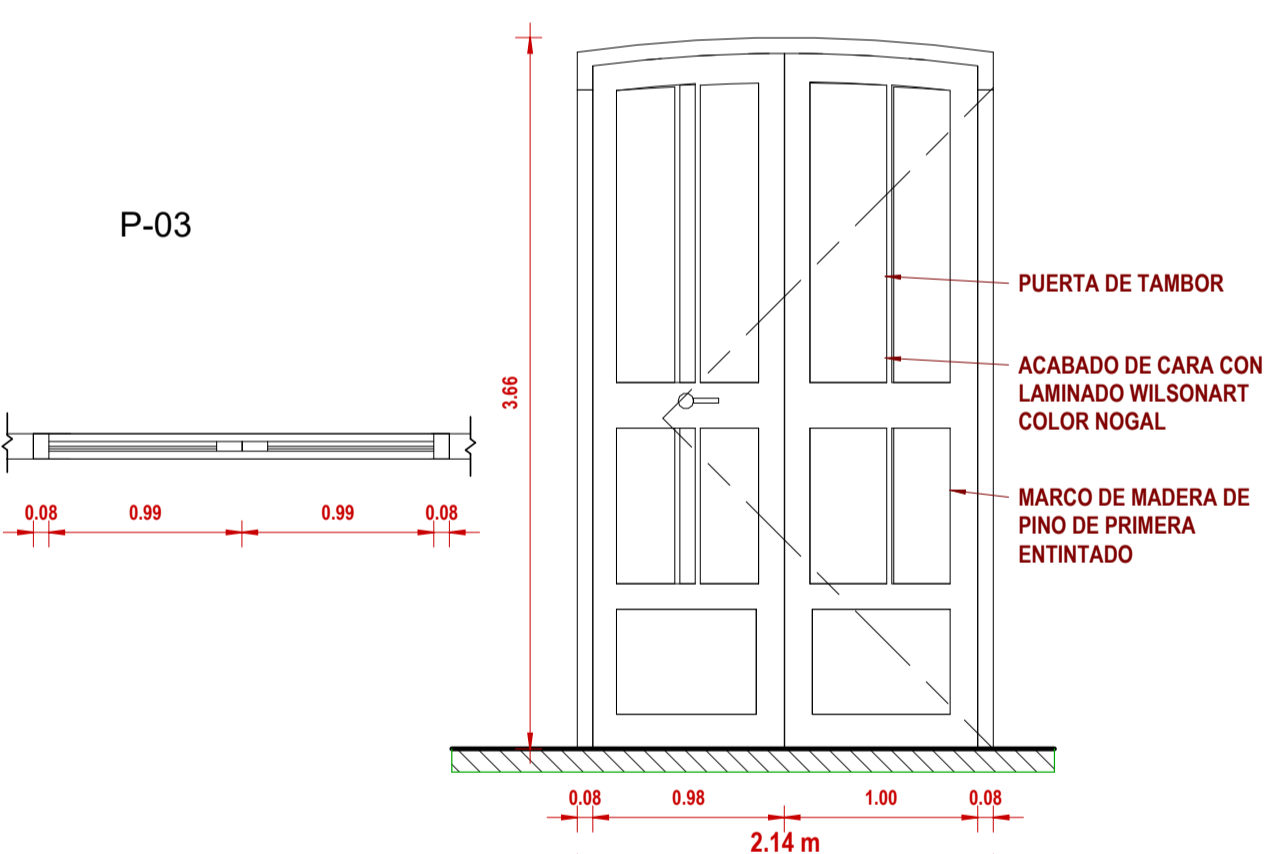
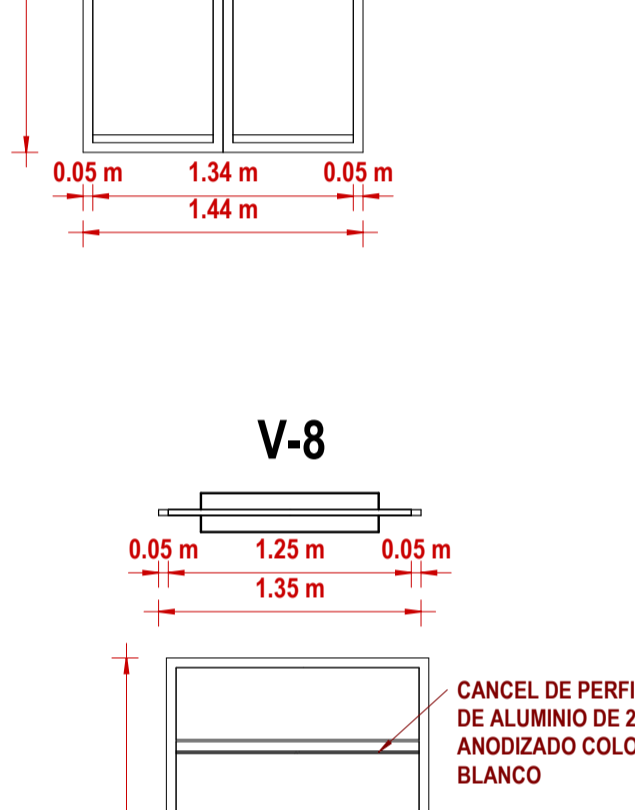
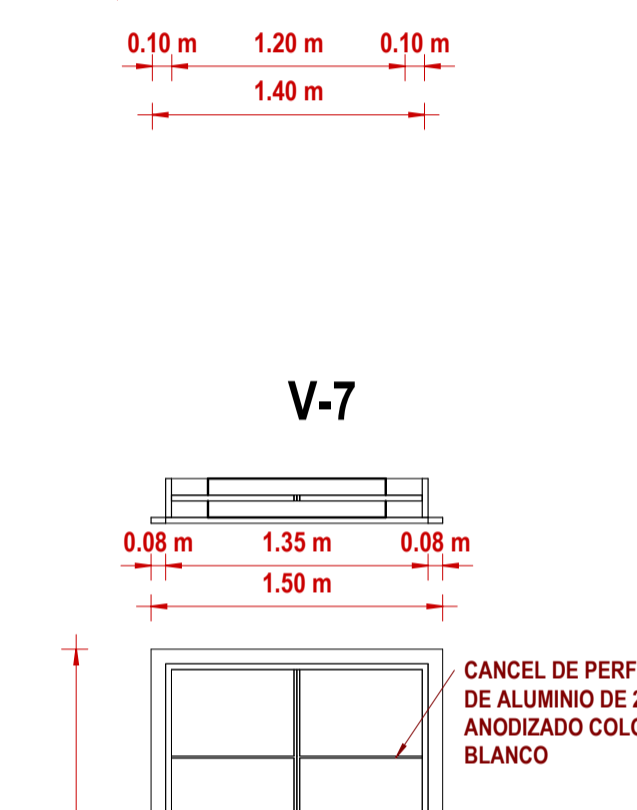
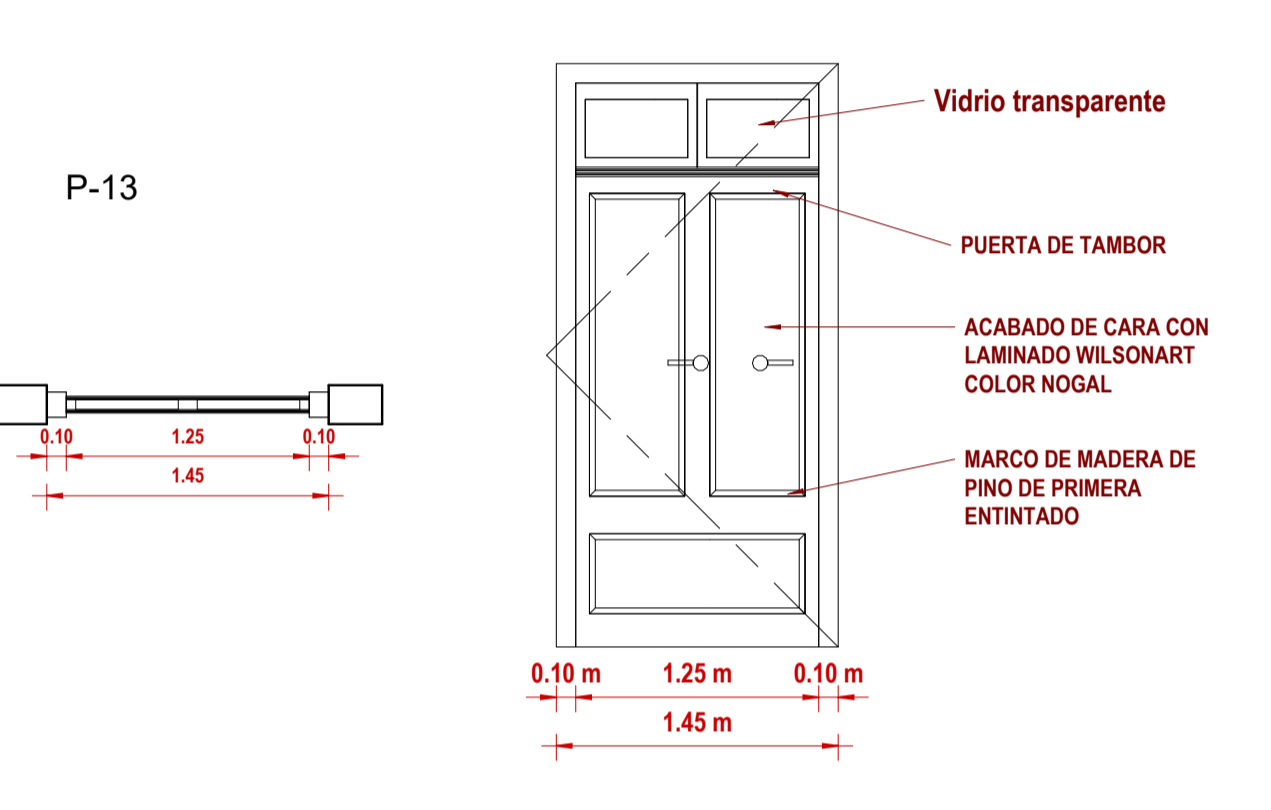
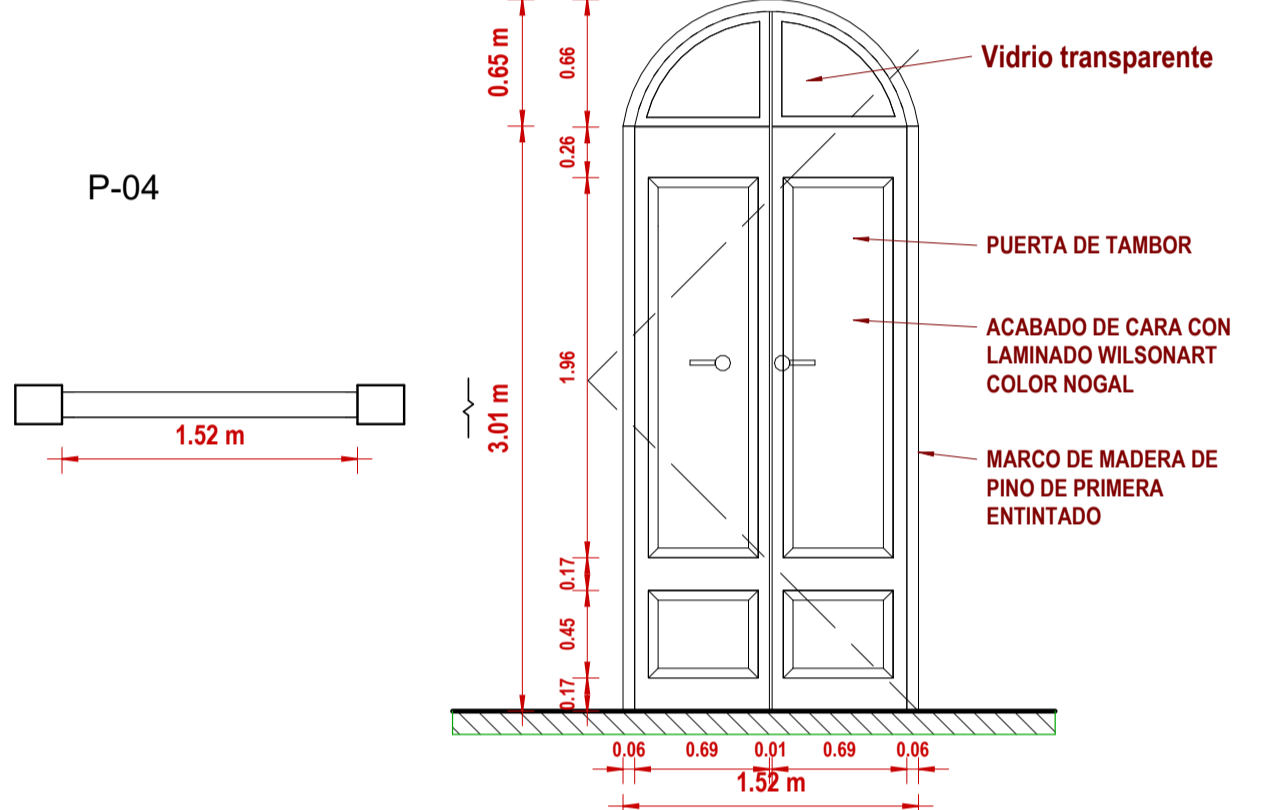
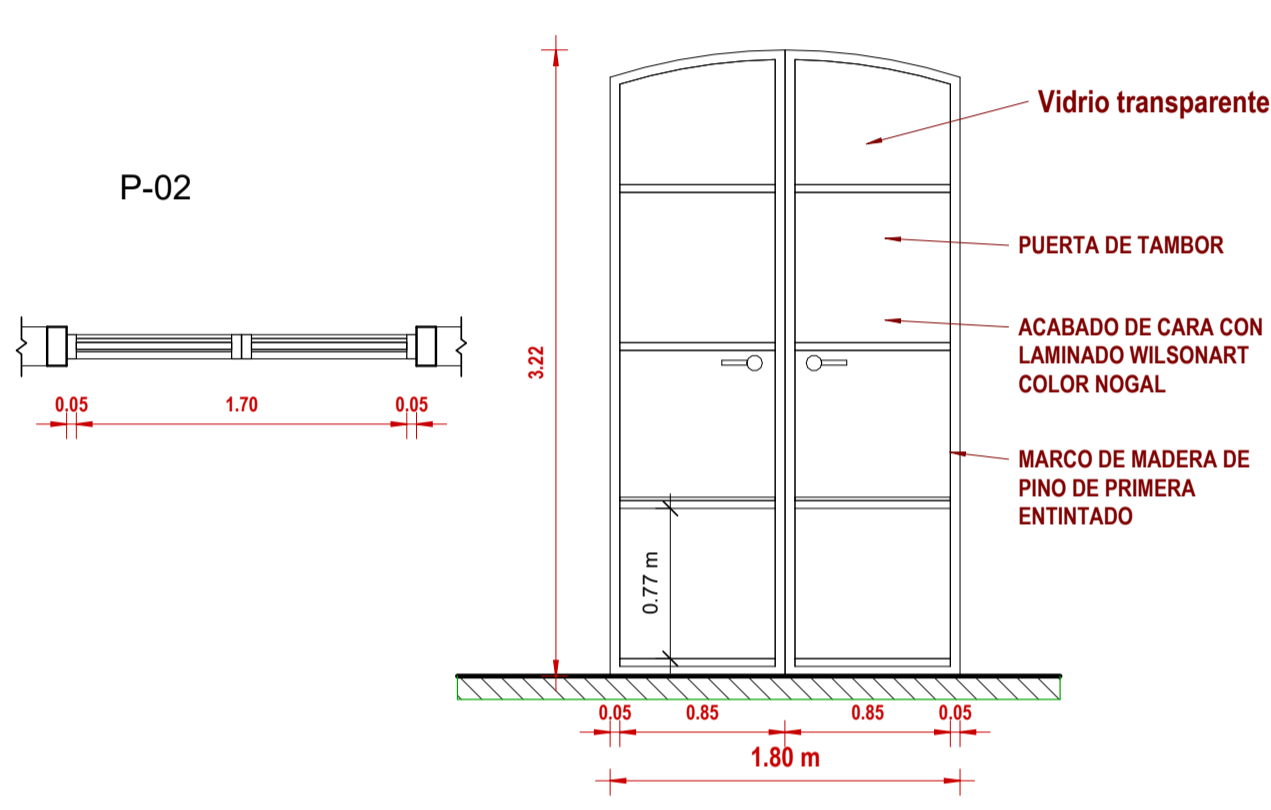
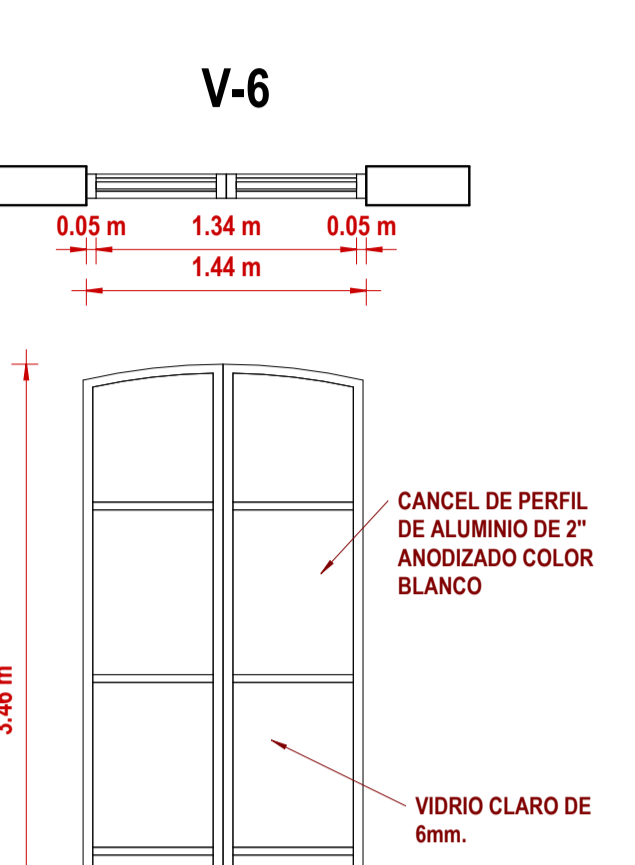
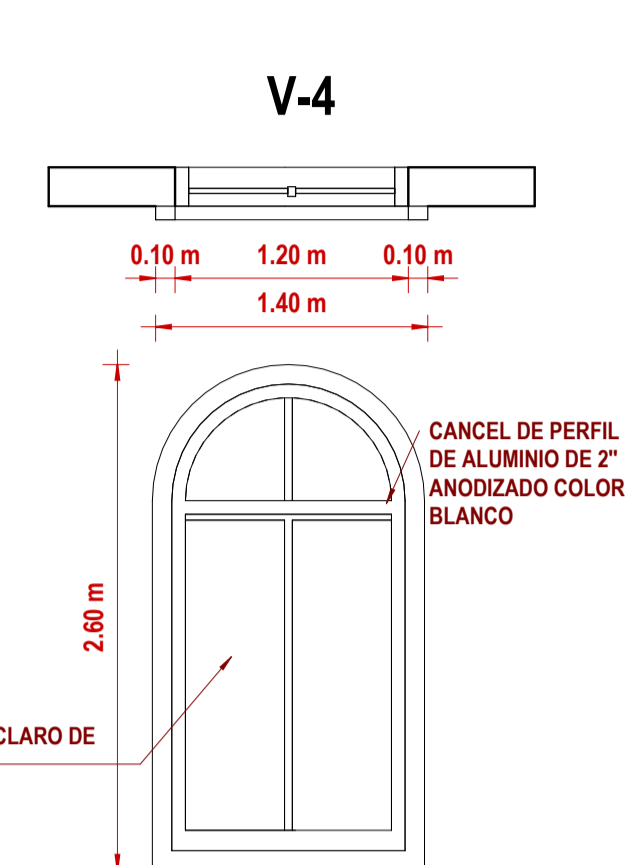
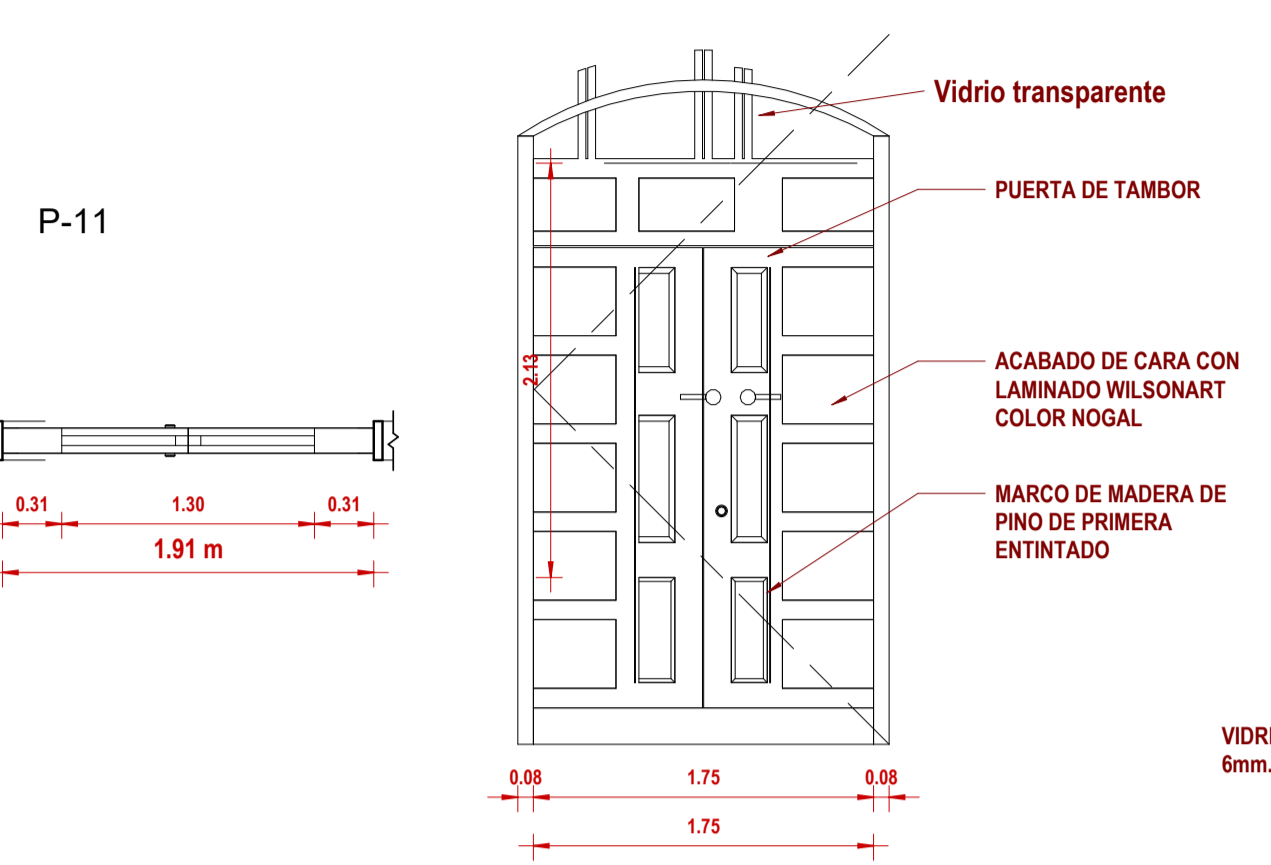
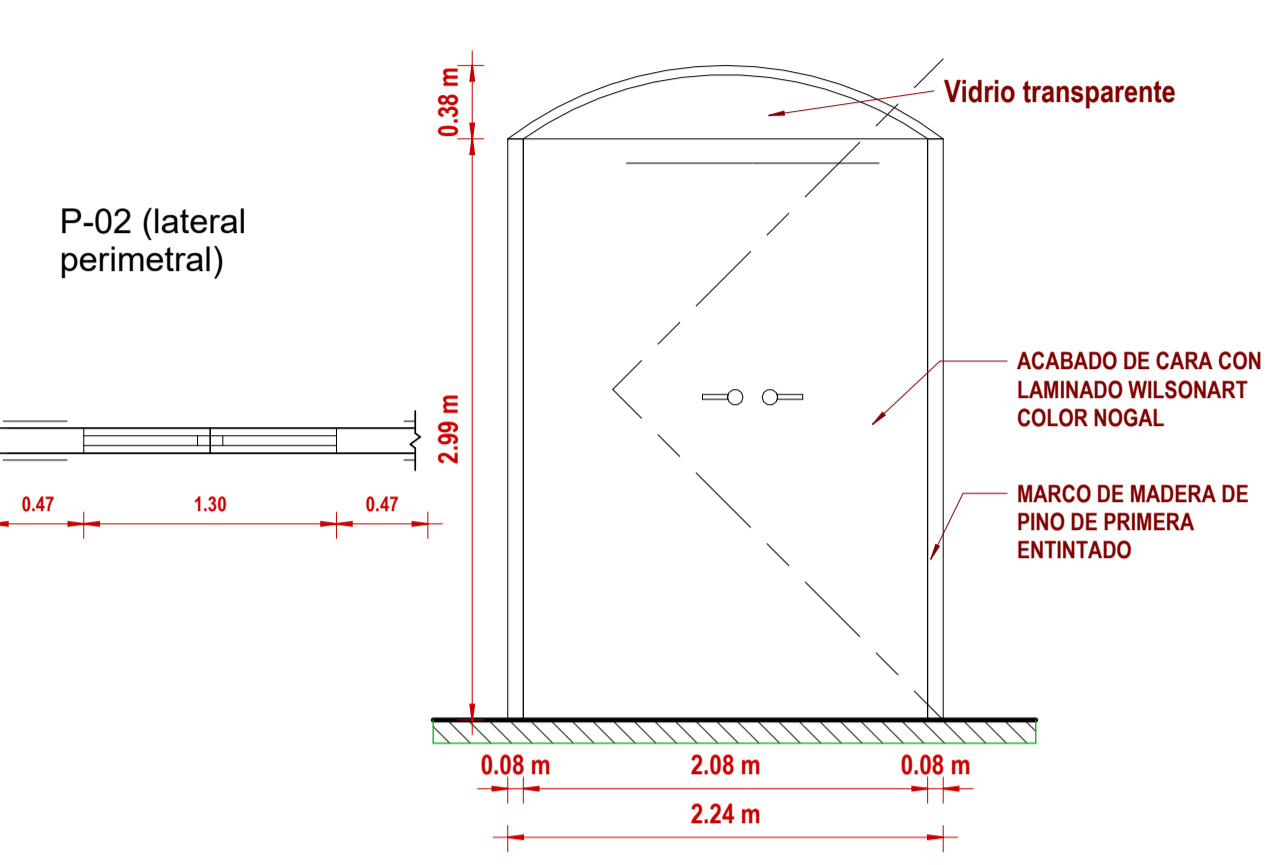
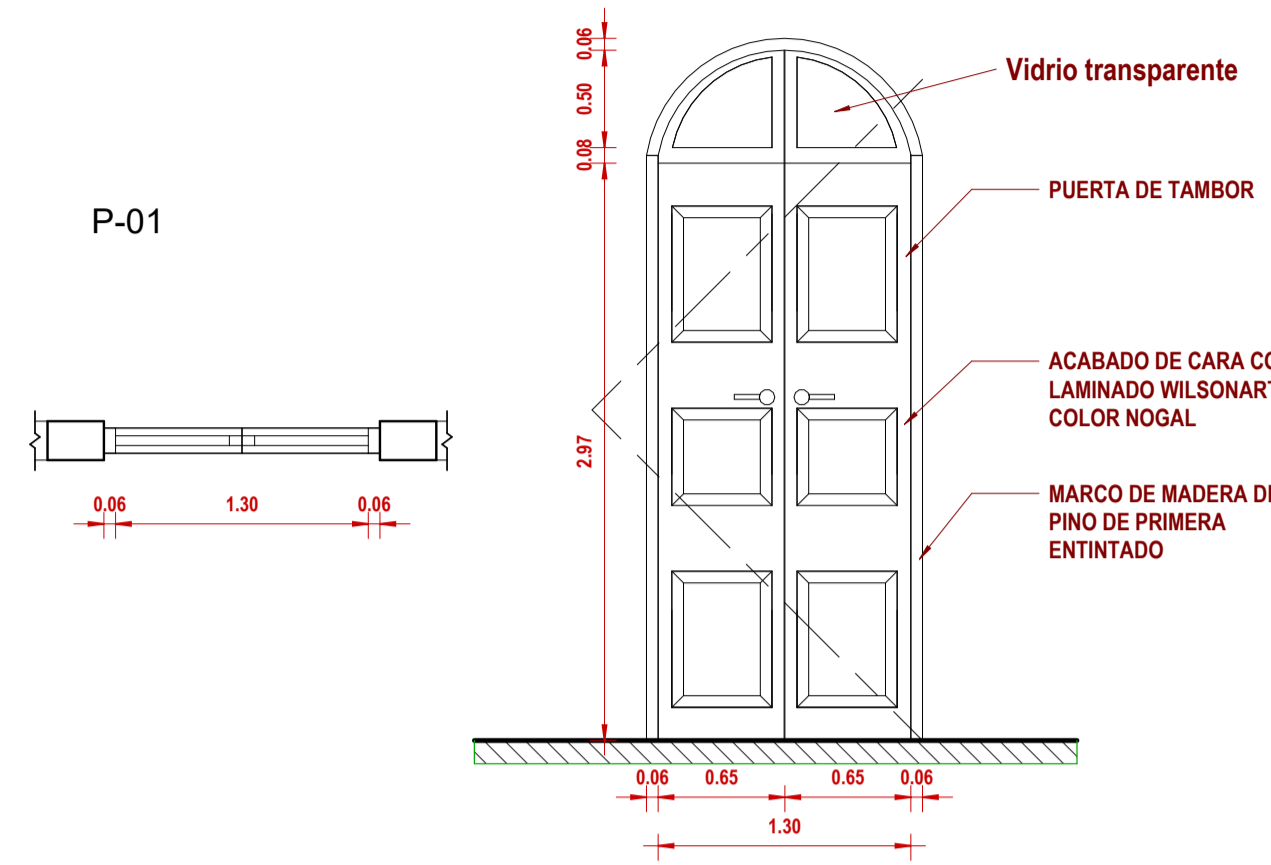

Detalle de PUERTA  
1 : 25

	<b>UNIVERSIDAD PRIVADA DE TACNA</b>		
	FACULTAD DE ARQUITECTURA Y URBANISMO		
	TESIS: "APLICACIÓN DE LA METODOLOGÍA BIM PARA LA GESTIÓN Y CONSERVACIÓN DEL PATRIMONIO CULTURAL: PREFECTURA Y CARCEL PÚBLICA DE TACNA, 2022"		
	I TALLER DE ASESORIA PERSONALIZADA PARA EL DESARROLLO DE TESIS DE INVESTIGACION EN ARQUITECTURA - MODALIDAD NO PRESENCIAL		
<b>DETALLE DE PUERTA Y VENTANA</b>			
ASESOR:	ARQ. ALDO RAUL GAMBETTA MONTALVO	TESISTA:	BACH. en ARQ. ROGER, QUENTA AMONES
ESCALA:	1/100	FECHA:	OCTUBRE 2022
			N. de LÁMINA: <b>A-DET-06</b>



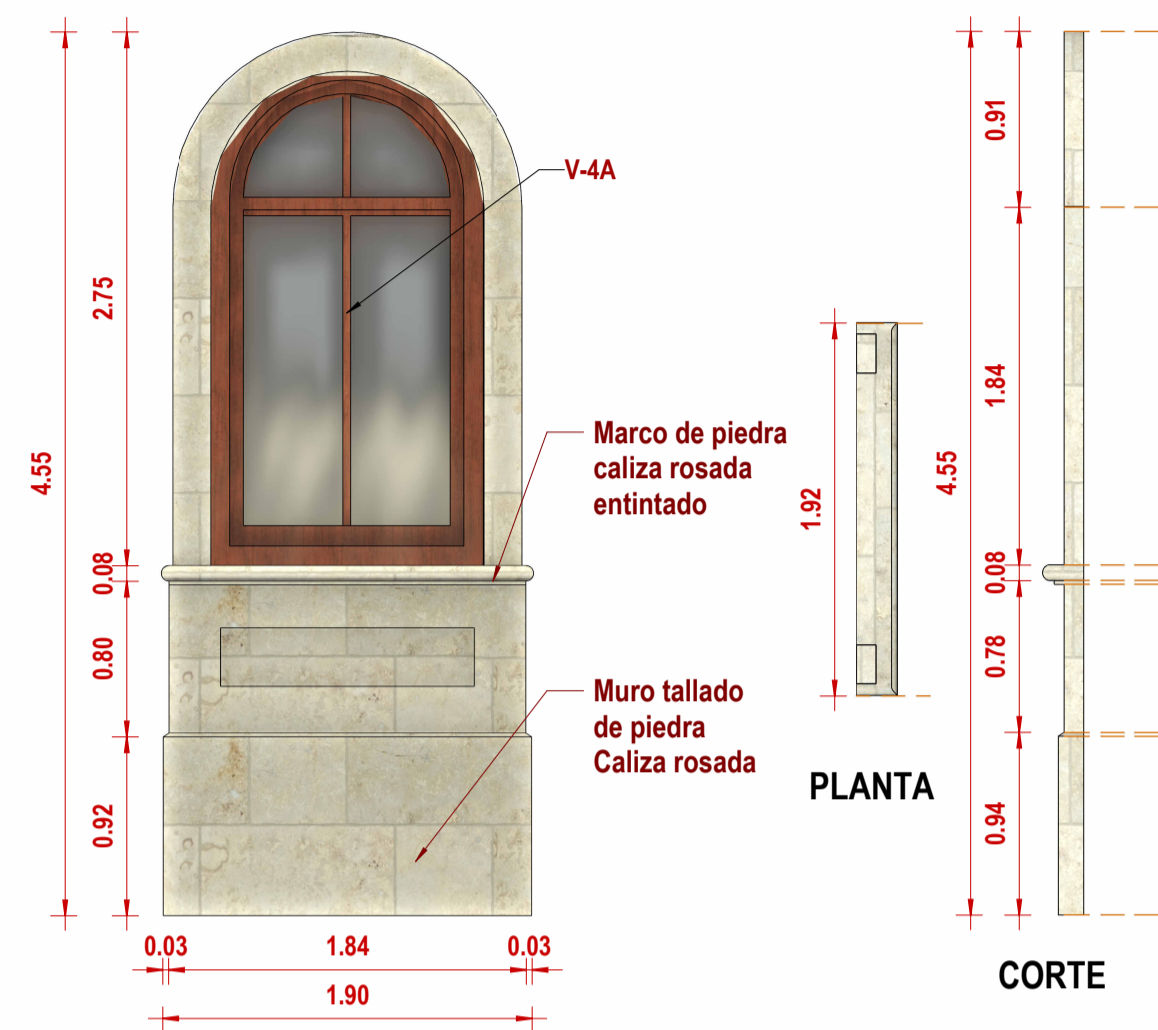

**ARCO DE MEDIO PUNTO**  
Esc. 1 : 25

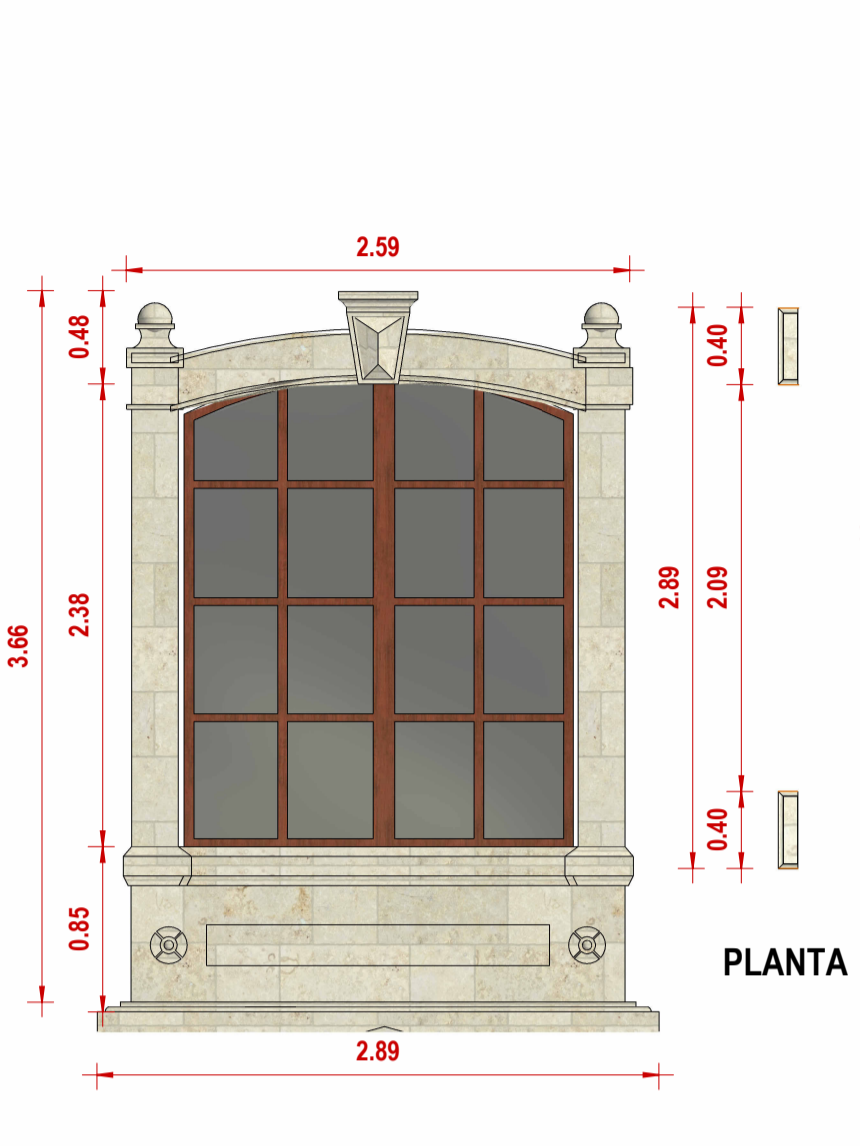

**ARCO SEGMENTARIO**  
Esc. 1 : 25

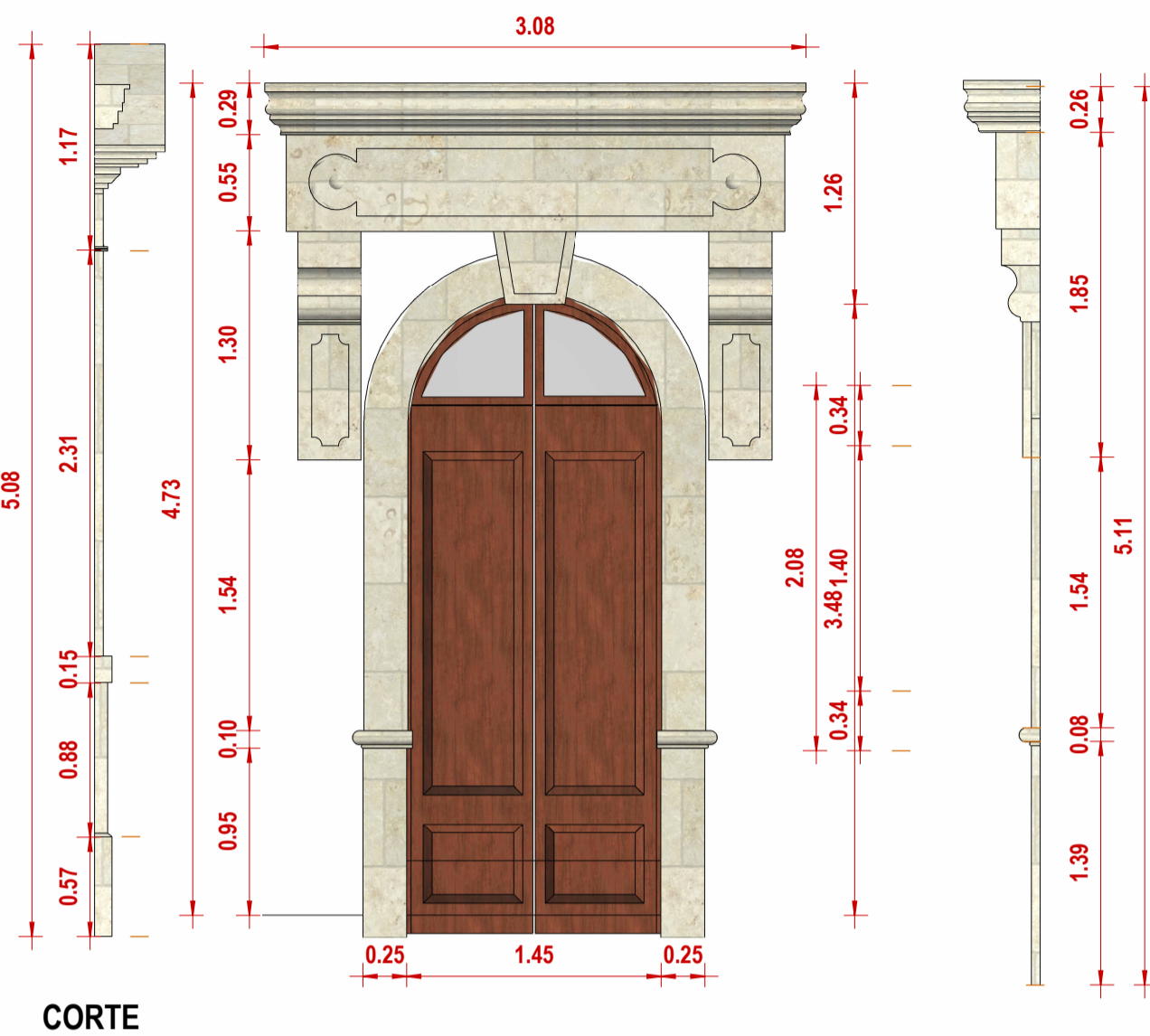

**FRONTON-05**  
Esc. 1 : 25

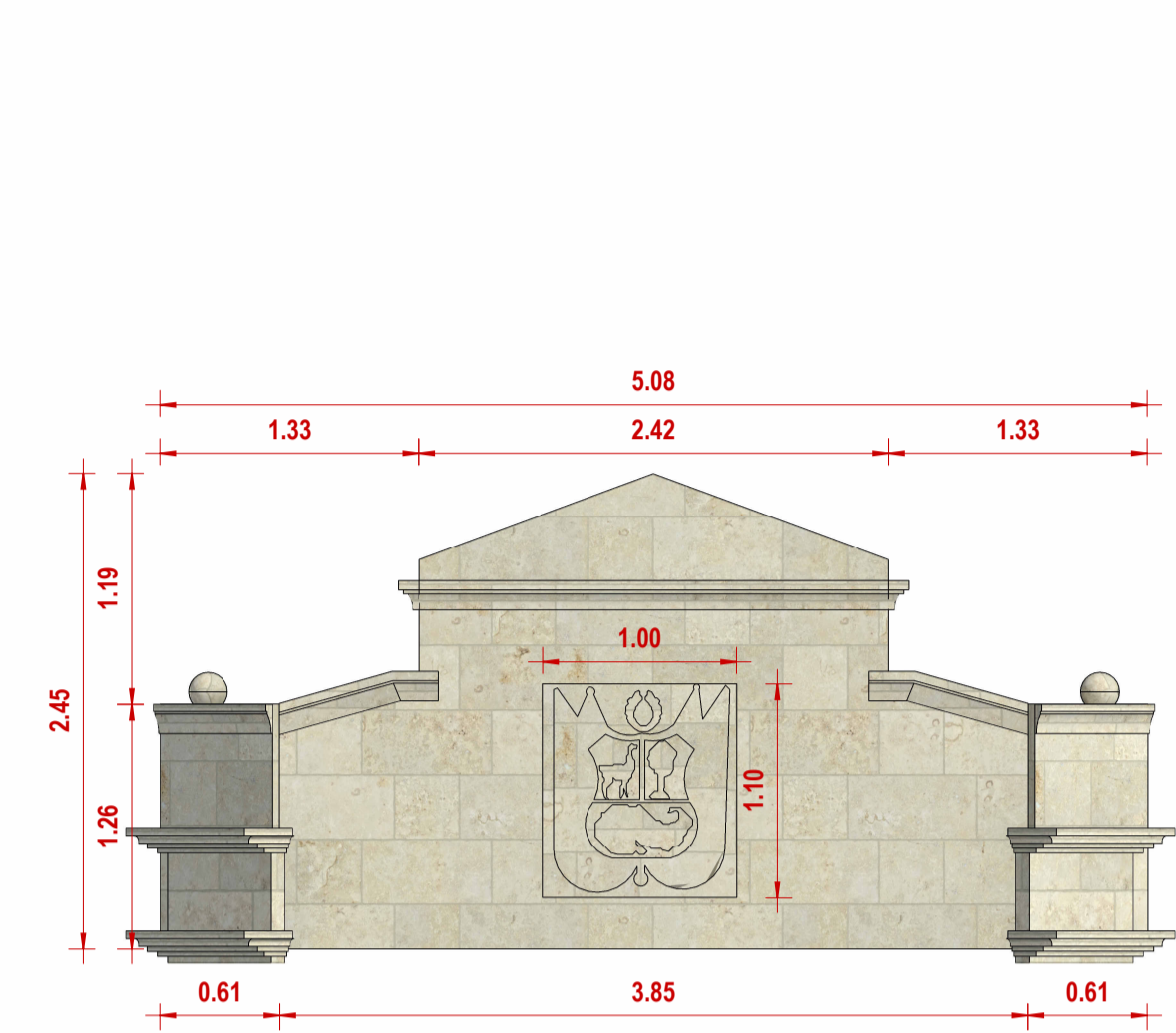

**FRONTON-11**  
Esc. 1 : 25

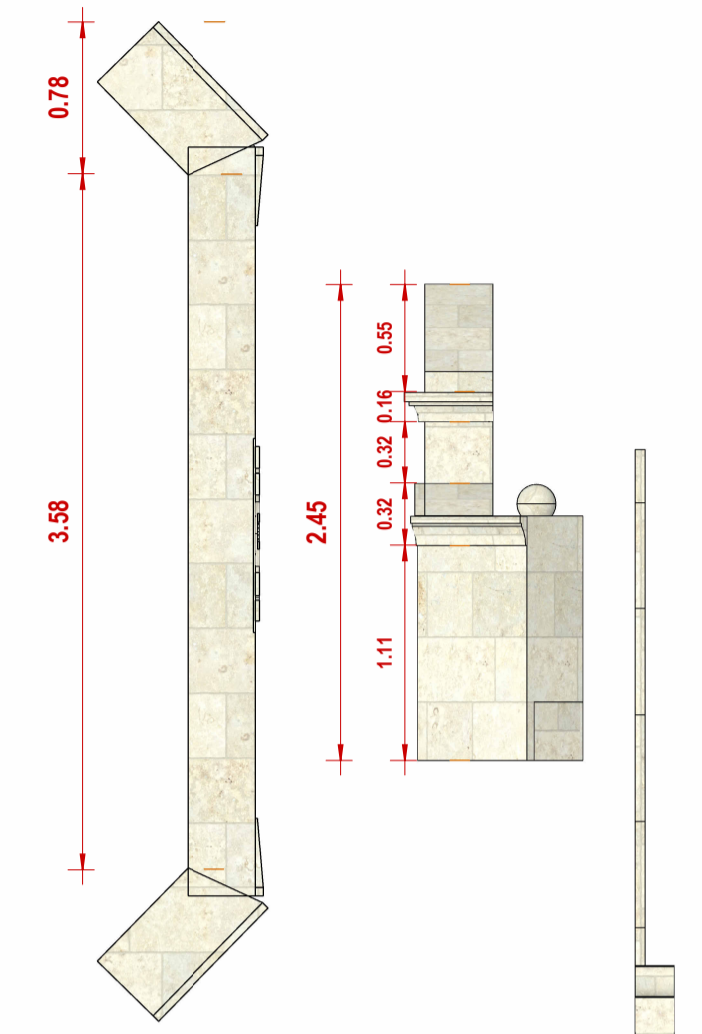

PLANTA

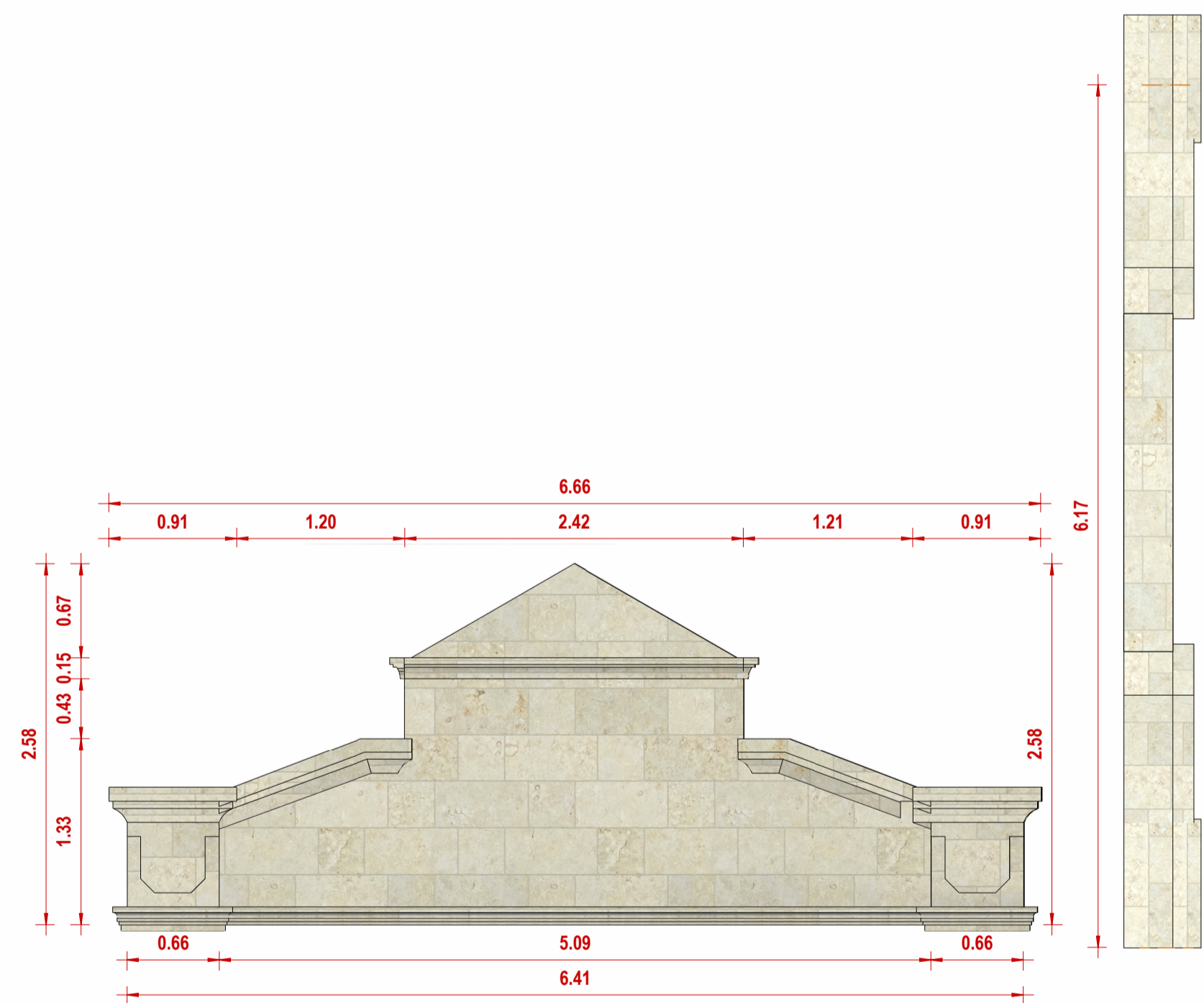

**FRONTON-12**  
Esc. 1 : 25

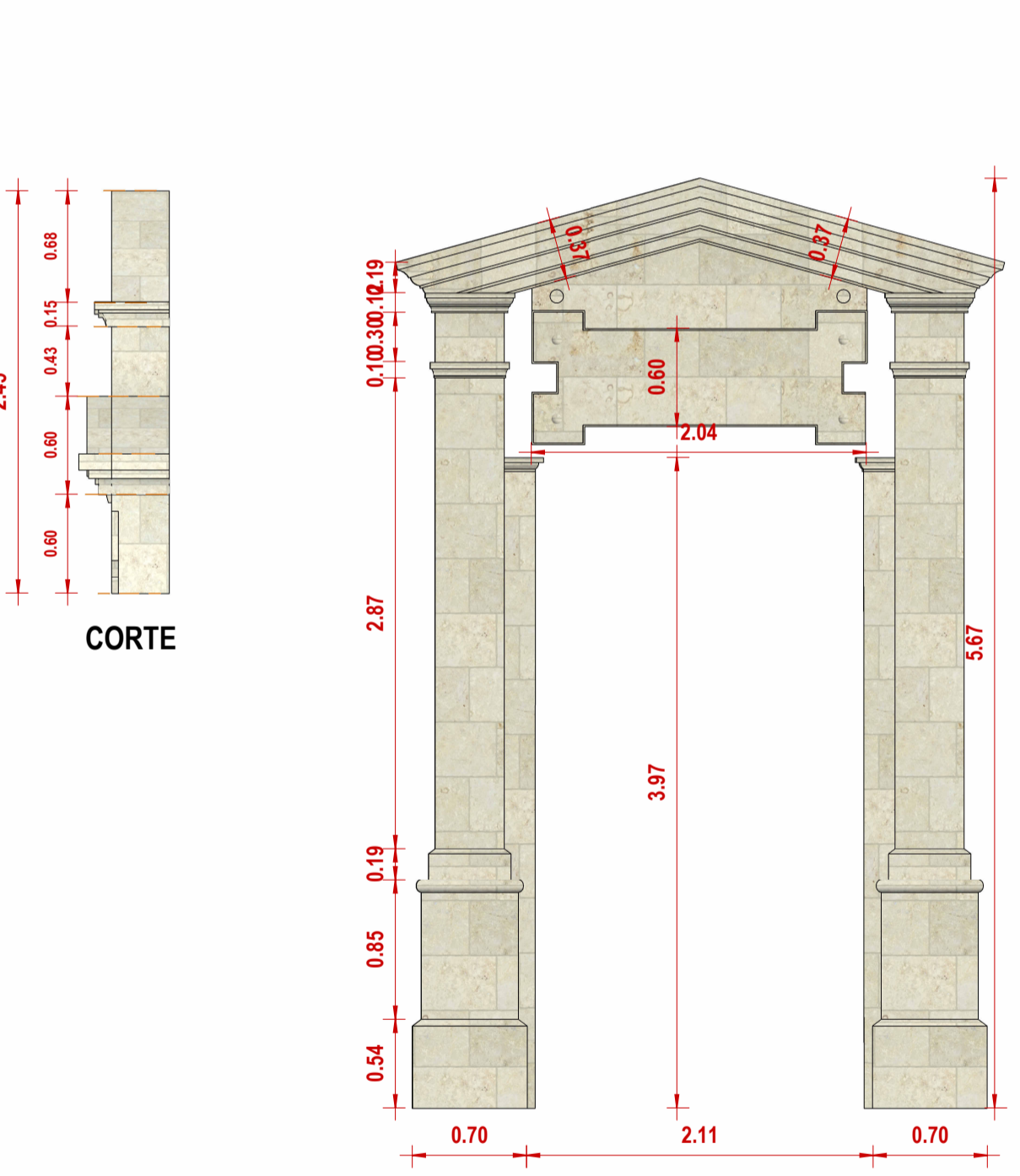

**FRONTON-13**  
Esc. 1 : 25

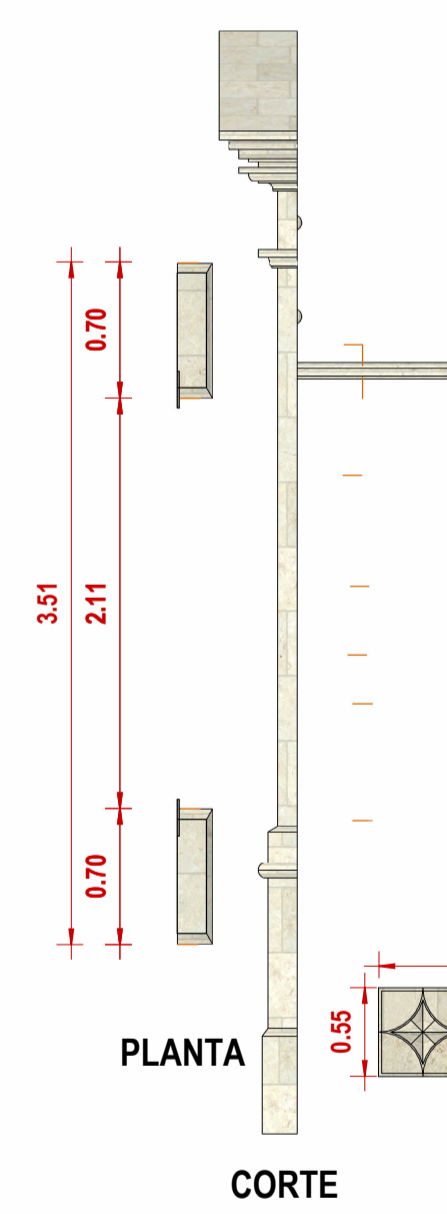

**REMATE - C. INCLAN**  
Esc. 1 : 30

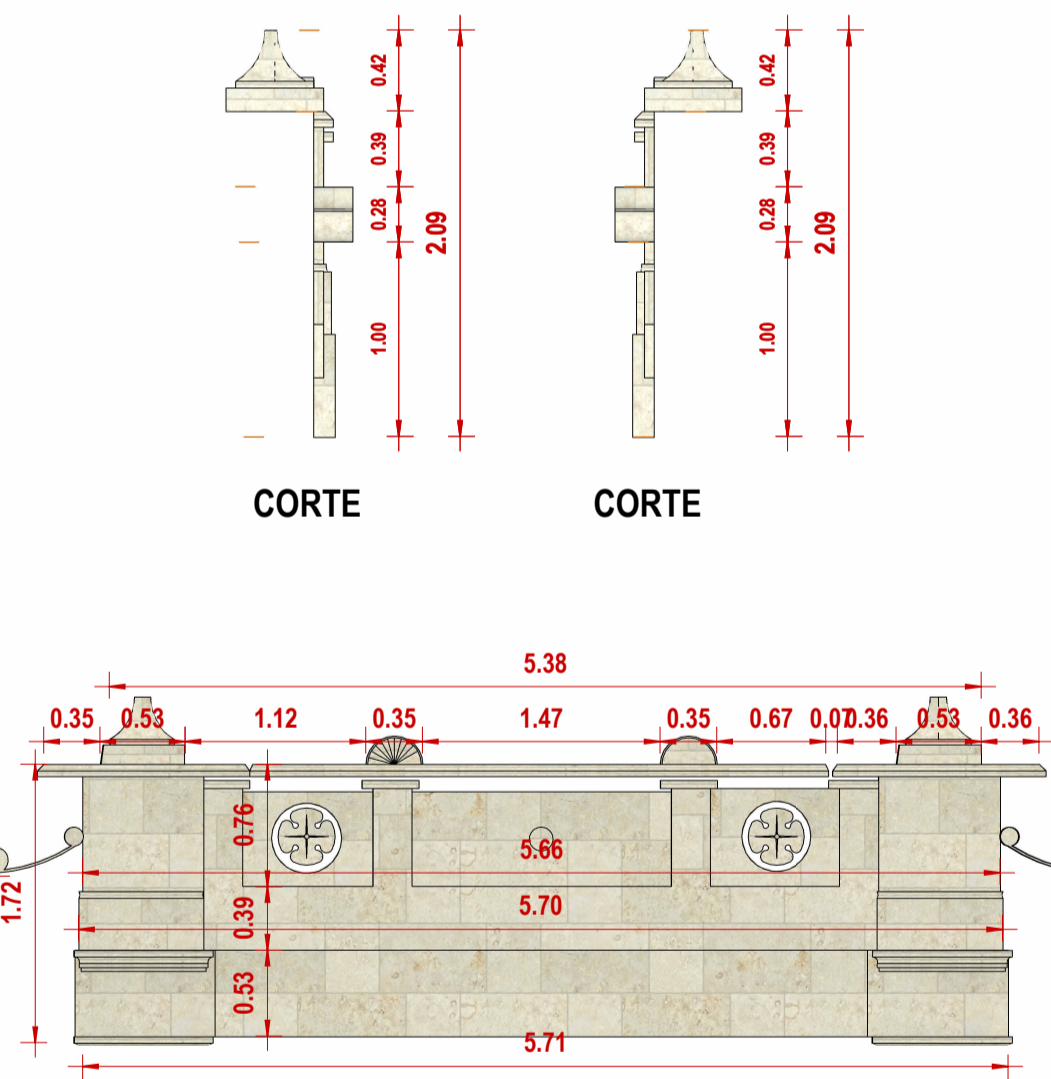

CORTE

CORTE

PLANTA

	<b>UNIVERSIDAD PRIVADA DE TACNA</b>		N° de LAMINA: <b>A-DE-07</b>
	FACULTAD DE ARQUITECTURA Y URBANISMO		
	TESIS: "APLICACIÓN DE LA METODOLOGÍA BIM PARA LA GESTIÓN Y CONSERVACIÓN DEL PATRIMONIO CULTURAL: PREFECTURA Y CARCEL PÚBLICA DE TACNA, 2022" I TALLER DE ASESORIA PERSONALIZADA PARA EL DESARROLLO DE TESIS DE INVESTIGACION EN ARQUITECTURA - MODALIDAD NO PRESENCIAL		
	<b>ELEMENTOS DECORATIVOS</b>		
ASESOR:	ARQ. ALDO RAUL GAMBETTA MONTALVO	TESISTA:	BACH. en ARQ. ROGER QUENTA AMONES
ESCALA:	1/100	FECHA:	OCTUBRE 2022